

INDUSTRIE

OMIA.FR

FABRICATION FRANCAISE

GRENAILLAGE // CABINE DE GRENAILLAGE PROJECTION D'ABRASIF

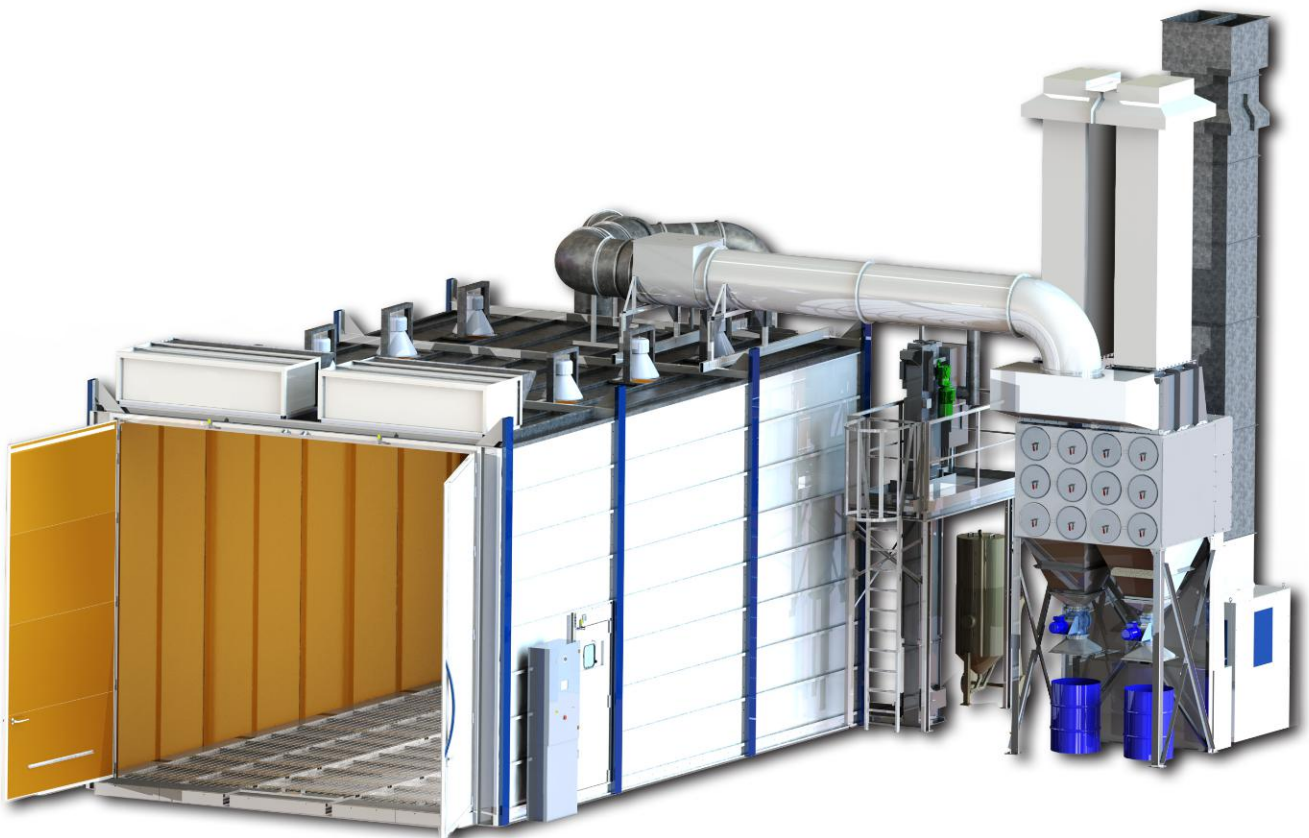

DESIGN - TECHNOLOGIES - INNOVATION

CABINE DE GRENAILLAGE

PROJECTION D'ABRASIF

Conçue pour le décapage de vos surfaces

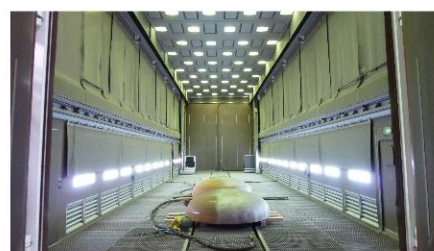
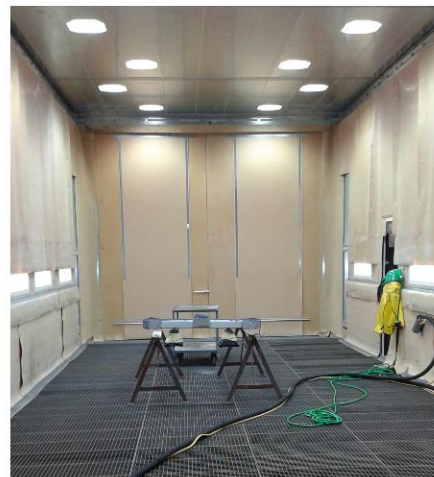

ETAPES DE FONCTIONNEMENT

- 1 → Projection de l'abrasif dans l'enceinte par l'opérateur
- 2 → Récupération de l'abrasif (avec et sans génie-civil)
- 3 → Recyclage et épuration de l'abrasif
- 4 → Dépoussiérage et filtration de l'air

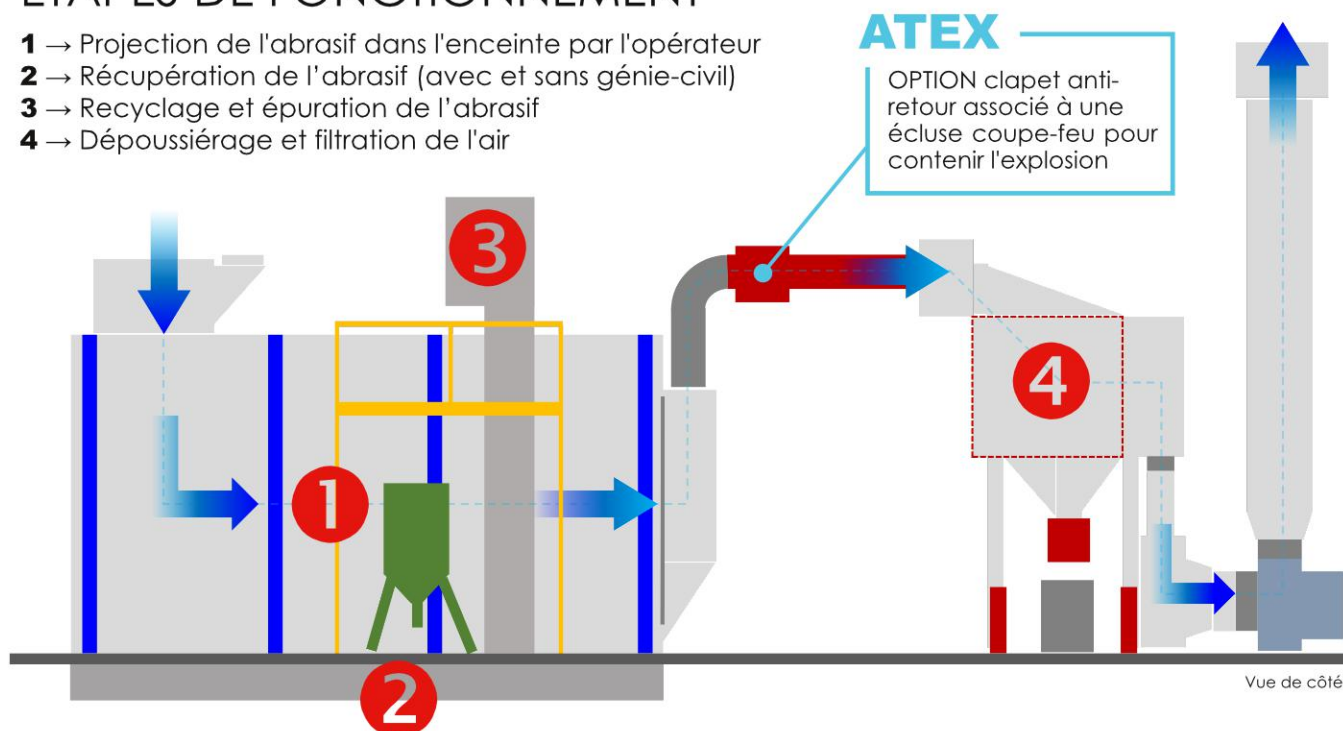

1

PROJECTION DE L'ABRASIF

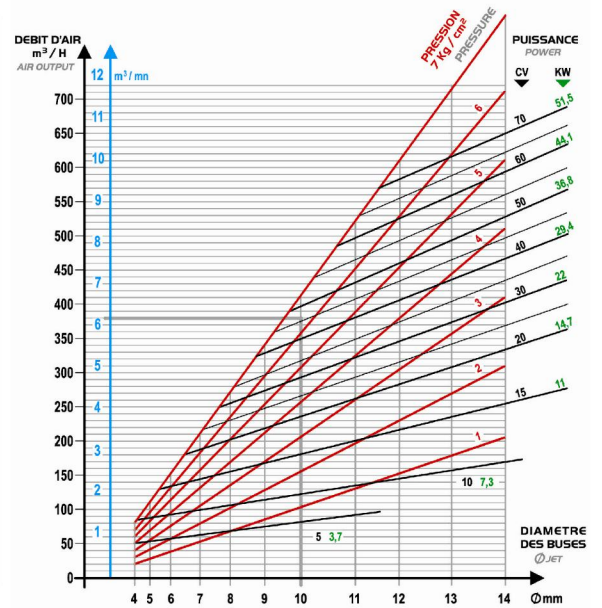
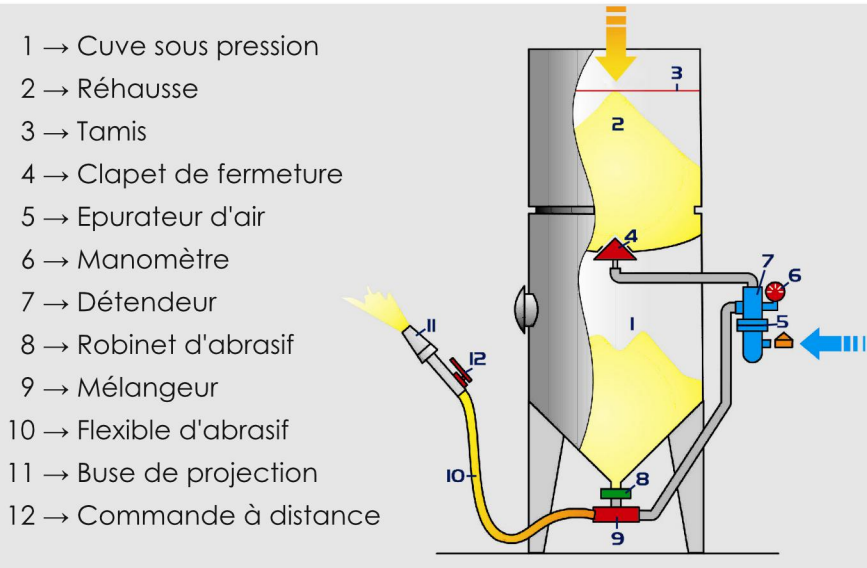

2

RECUPERATION DE L'ABRASIF

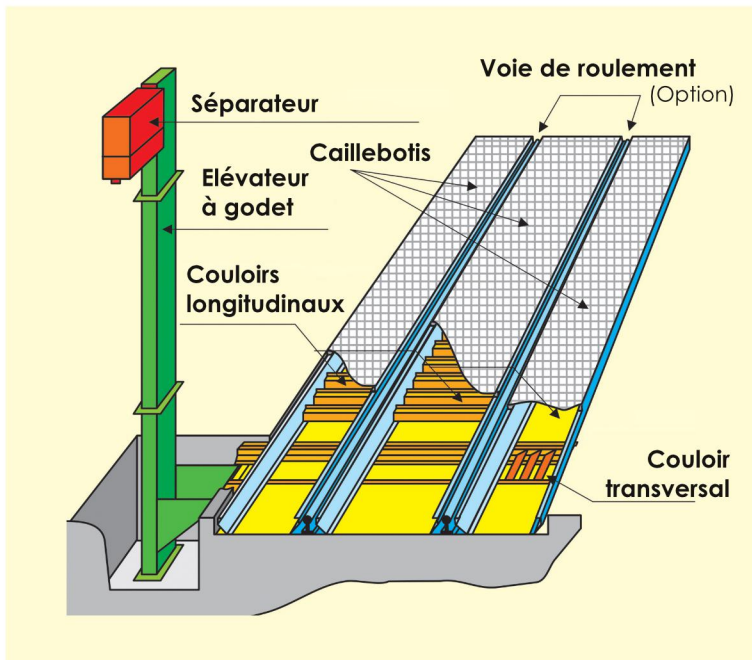

- Aucun organe mécanique dans le milieu abrasif
- Articulation souple brevetée sans entretien

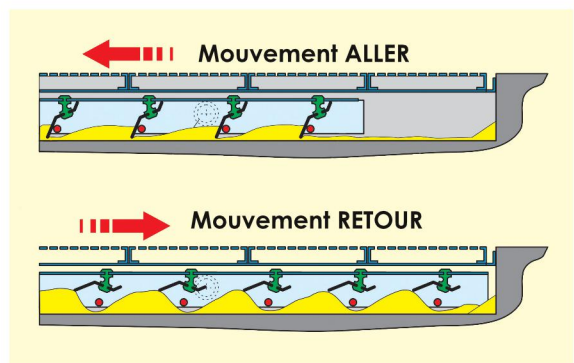

→ Récupération localisée



→ Récupération partielle

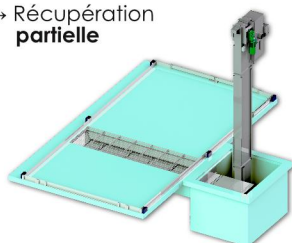

→ Récupération optimale

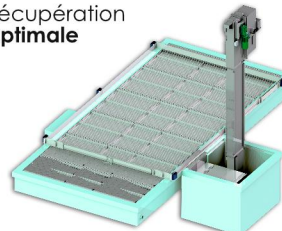

→ Récupération optimale Sans génie-civil



3

RECYCLAGE & EPURATION DE L'ABRASIF

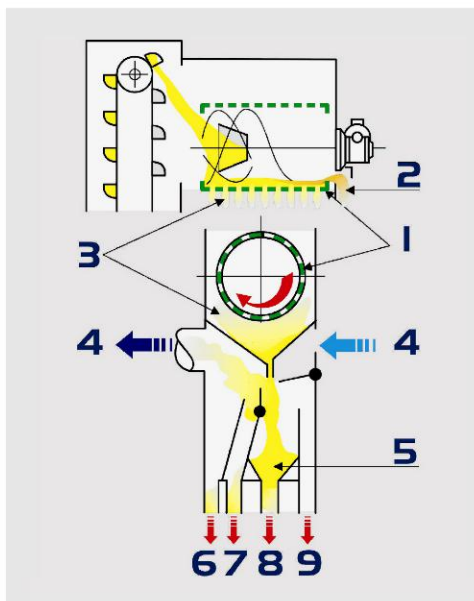

- 1 → Trommel
- 2 → Elimination gros déchets
- 3 → Abrasif avec poussières
- 4 → Sens de circulation de l'air
- 5 → Abrasif épuré
- 6 → Déchets fins
- 7 → Recyclage
- 8 → Alimentation sableuse
- 9 → Trop plein vers pied élévateur

4

DEPOUSSIERAGE & FILTRATION DE L'AIR

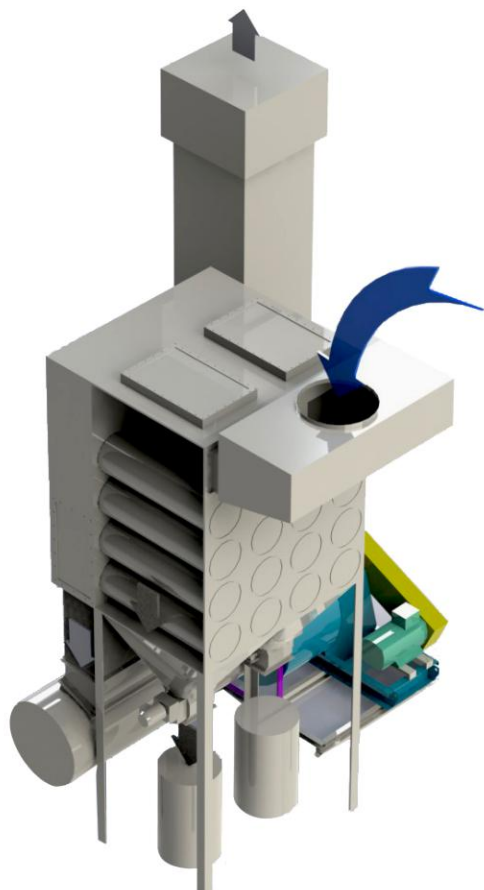

→ Epuration de l'air par **cartouches filtrantes** à décolmatage automatique en continu

Exemples de REALISATIONS

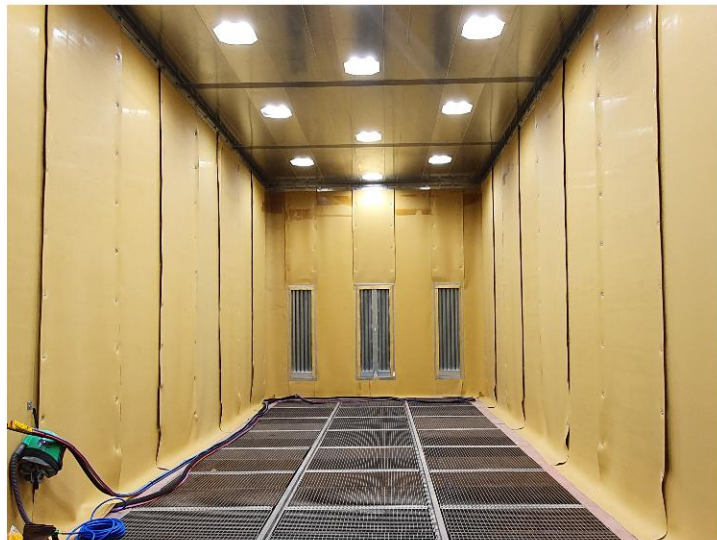
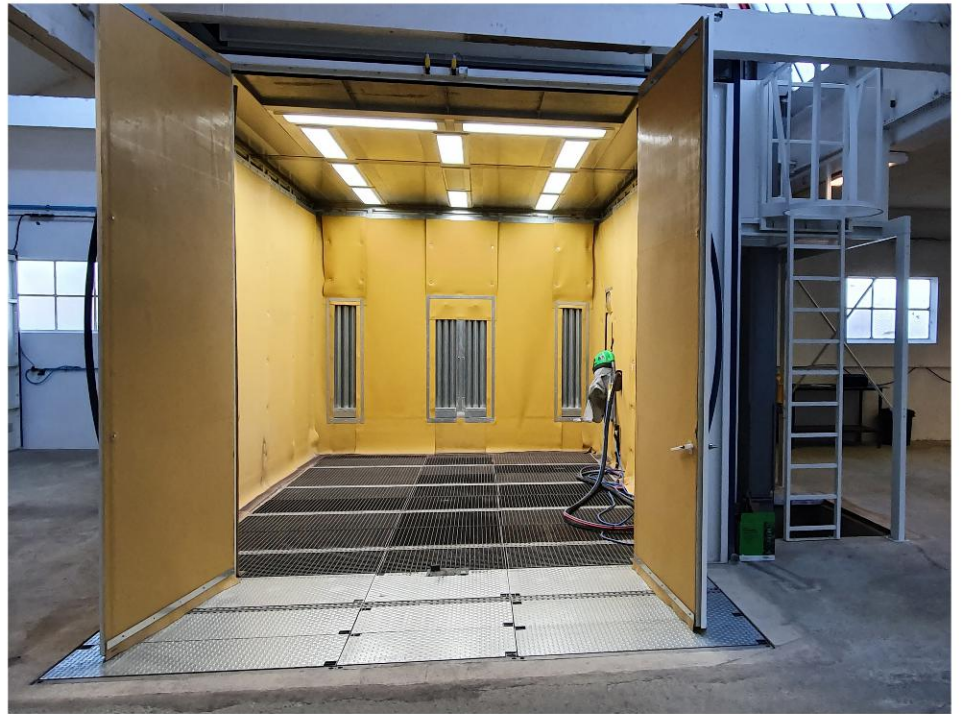

Chaînes de traitement de surface

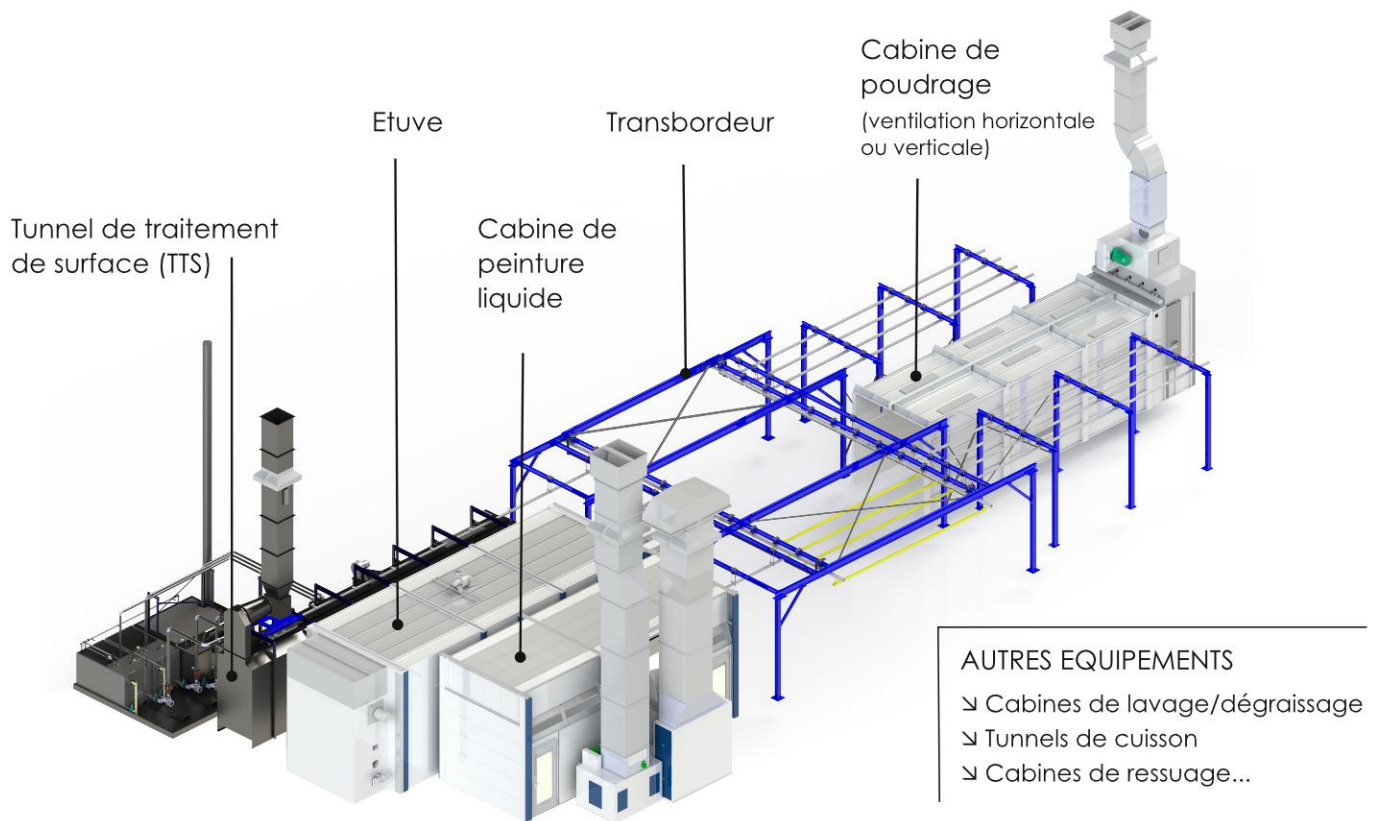

SERVICE APRES-VENTE



40 Techniciens spécialisés en région

HOT-LINE France
0 811 656 659

- Dépannages et assistance technique par HOT-LINE (France et international)
- Mises en service (neuf et occasion)
- Contrats de maintenance
- Fournitures pièces détachées
- Approvisionnements consommables

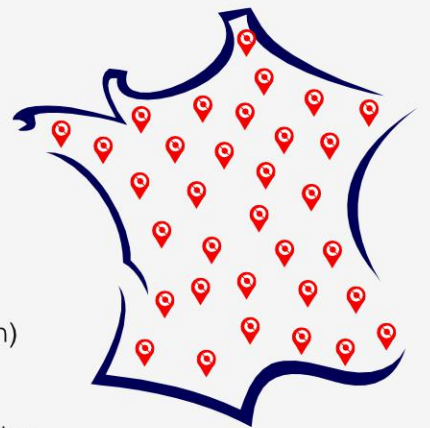

DESIGN - TECHNOLOGIES - INNOVATION

ZI N°3, 66 avenue Maryse Bastié,
16340 L'ISLE D'ESPAGNAC, France
+33 (0)5 45 20 51 90 // omia@omia.fr // www.omia.fr